

IM-2-23-PB0

Electrical specifications

Winding code : PB	Symbol	Unit	Field weakening & Water cooling
Continuous torque	T_c	Nm	49.8
Continuous current	I_c	A_{rms}	20.4
Stall torque	T_s	Nm	42
Stall current	I_s	A_{rms}	16.3
Peak torque(for 1sec.)	T_p	Nm	76
Peak current(for 1sec.)	I_p	A_{rms}	51
Torque constant	K_t	Nm/A_{rms}	2.77
Electrical time constant	T_e	ms	7.1
Resistance (line to line at 25°C)	R_{25}	Ω	0.9
Inductance (line to line)	L_d / L_q	mH	6.4 / 9.41
Number of poles	2p		22
Back emf constant (line to line)	K_v	$V_{rms}/rad/s$	1.6
Motor constant (at 25°C)	K_m	Nm/\sqrt{W}	2.38
Thermal resistance	R_{th}	K/W	0.187
Thermal sensor			PTC SNM100+SNM130+Pt1000
Max. DC BUS	V_{DC}		750
Inertia of rotor	J	kgm^2	0.0051
Thermal time constant	T_{th}	s	230
Max. continuous power dissipation	P_c	W	792
Max. peak power dissipation	P_p	W	4954
Max. speed(at 600VDC)		rpm	5450
Based speed(at 600VDC)		rpm	1903
Rated speed(at 600VDC)		rpm	5450

T-N curve

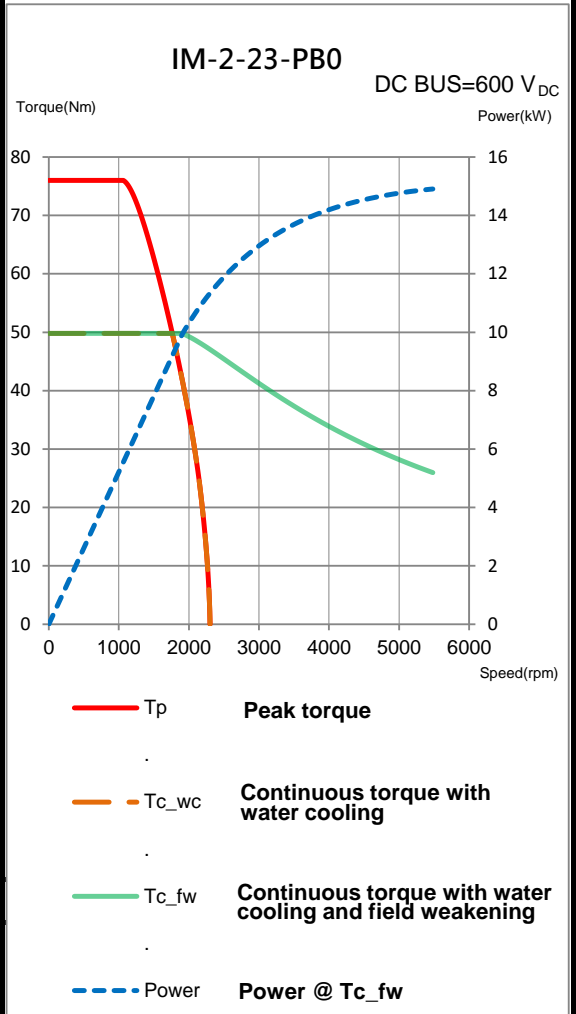

Mechanical specifications

	Symbol	Unit	Field weakening & Water cooling
Mass of rotor	M_r	kg	2.74
Mass of stator	M_s	kg	6.5
Height of stator	H_s	mm	80
Height of rotor	H_r	mm	51
Length of rotor centring fit	H	mm	15
Water temperature difference for P _c	$\Delta\theta$	K	5
Minimum water flow	q	l/min	2.3
Max. pressure drop	Δp	bar	1

Thermal sensor

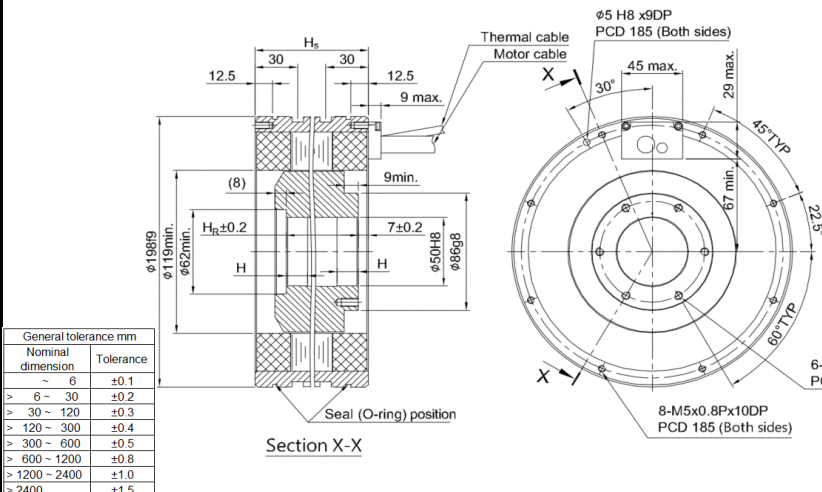
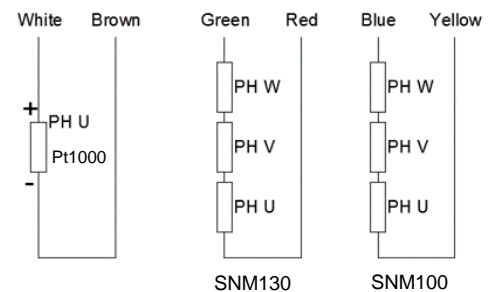

Motor wire table	
Color or wire no.	Signal
U/L1	PH U
V/L2	PH V
W/L3	PH W
Green/Yellow	GND

Except dimensions, all the specifications in the table are in ±10% of tolerance

Version: 2.00

This drawing is only for reference, detail dimensions please refer to approval drawing.

Date: 2020/10/23